

SETTING NEW
STANDARDS



HYPER
GRINDER

HGE
650
M/RX/AD



MADE IN ITALY

HGE 650 M/RX/AD



REMOTE CONTROL WITH
AUTOPILOT SYSTEM FOR
AUTODRIVE VERSION

HGE650 M/RX/AD

Remote-controlled planetary grinding and polishing machine for large surfaces, with variable speed, adjustable working pressure, on board batteries for autonomous movement and autopilot system.

Main technical features:

- Adjustable working pressure.
- Tempered stainless steel planetary and gear box. Fully geared transmission.
- Third wheel for easy transportation and for operations on very large surfaces.
- Compact and handy.
- Automatic planetary lifting to facilitate loading and unloading procedures from vehicles.
- All functions available on remote controls.
- On board batteries for machine self displacement.
- Magnetic quick tool attachment system.

Applications:

- Smoothing and preparation of all types of floors.
- Unevenness removal on concrete.
- Removal of resins, glues, paints and other residues.
- High glossy mirror look polishing of marble and granite.
- High glossy mirror look polishing of industrial concrete floors.

OPTIONAL:

- kit front and rear led lights. (HG105401)
- kit extra weights 45Kg. (HG161401)
- kit sprayer. (HG132701)
- kit ring with bristles and squeegee. (HG1078803)

TECHNICAL DATA

Model	Motor	Drive Inverter	Volt	Hertz	Amp	Tools Speed	Work Diameter	Tools Size	Water Tank	Size LxAxP cm	Weight
HGE 650 M	10 HP	11 kW	380-480	50/60	25	300-1300 rpm	650mm	3x240mm	46 lt	140x145x68	--
HGE 650 M	15 HP	11 kW	380-480	50/60	25	300-1300 rpm	650mm	3x240mm	46 lt	140x145x68	510 Kg
HGE 650 RX	15 HP	11 kW	380-480	50/60	25	300-1300 rpm	650mm	3x240mm	46 lt	140x145x68	615 Kg
HGE 650 AD	15 HP	11 kW	380-480	50/60	25	300-1300 rpm	650mm	3x240mm	46 lt	140x145x68	615 Kg



Remote-controlled planetary grinding and polishing machine for large surfaces, with variable speed, adjustable working pressure, on board batteries and autopilot system.

Anti-shock system for maximum reliability.

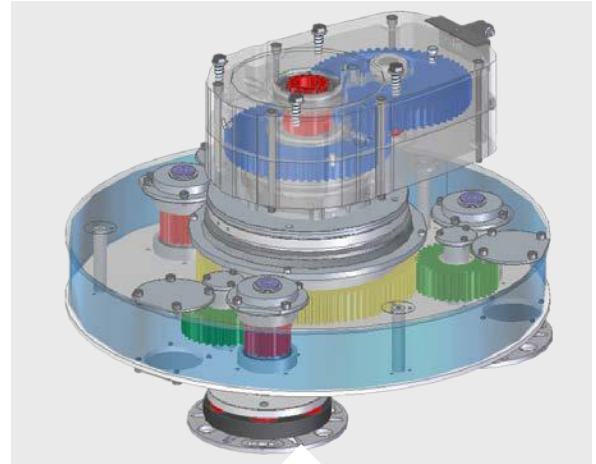
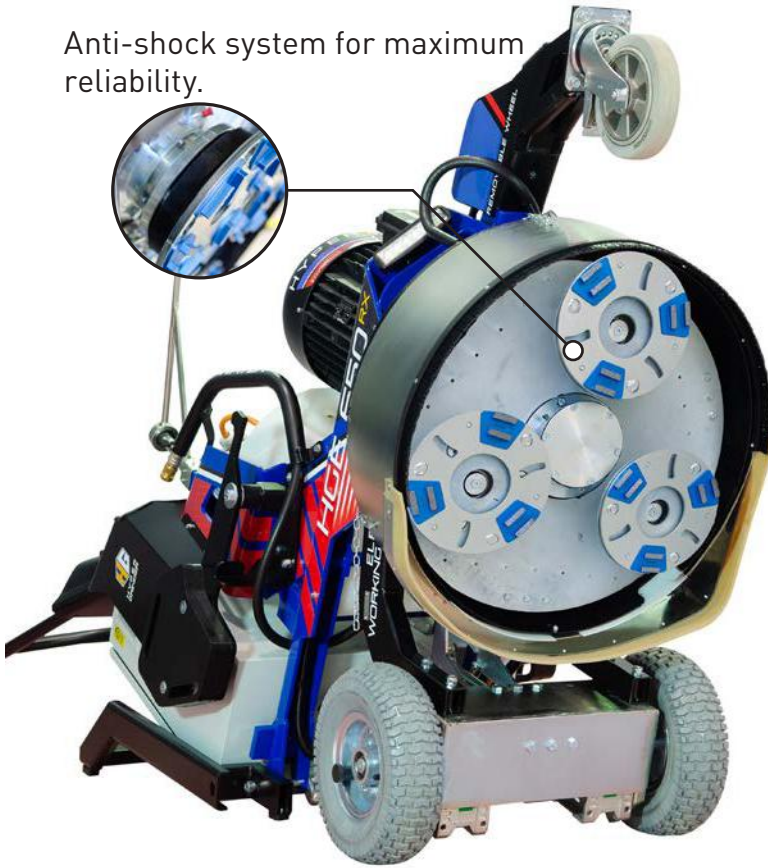

FULL METAL GEAR BOX

PLANETARY HEAD that is 100% tempered metal and geared driven not belt.



THIRD FRONT WHEEL

- Facilitates transport, loading and unloading.
- It is very useful when working on very irregular surfaces.

ESTIMATED PRODUCTION

Concrete Polishing 7 step	20-25m ² /h
Concrete Grinding 1 step	50-100m ² /h
Terrazzo Polishing 5 step	20-30m ² /h
Resin Removal 1 step	80-120m ² /h
Paint Removal 1 step	80-120m ² /h
Marble Polishing 5 step	12-25m ² /h
Granite Polishing 7 step	8-10m ² /h

Data may vary depending on surface conditions, tools used, operator convenience, equipment, etc.



Volume
2,27 m³

Size
88x163x158cm

Weight
680 Kg



ELECTRONICALLY ADJUSTABLE WORKING PRESSURE The HG HYPER GRINDER system allows increased manoeuvrability of the planetary, guaranteeing greater productivity and greater surface flatness.

AUTODRIVE

THE HIGHEST TECHNOLOGY AVAILABLE ON THE MARKET
FOR GRINDING MACHINES FOR FLOORS.

AUTODRIVE FUNCTIONS SYSTEM

- Working pressure adjustable by radio control.
- Operates without power supply.
- Great driving power.
- Automatic tilting (Swing movement).
- Automatic reversal of travel (U-Turn).
- Automatic grinding of the entire surface.
- Manoeuvres and grinds edges with precision.
- Manoeuvrability at the top of the category.

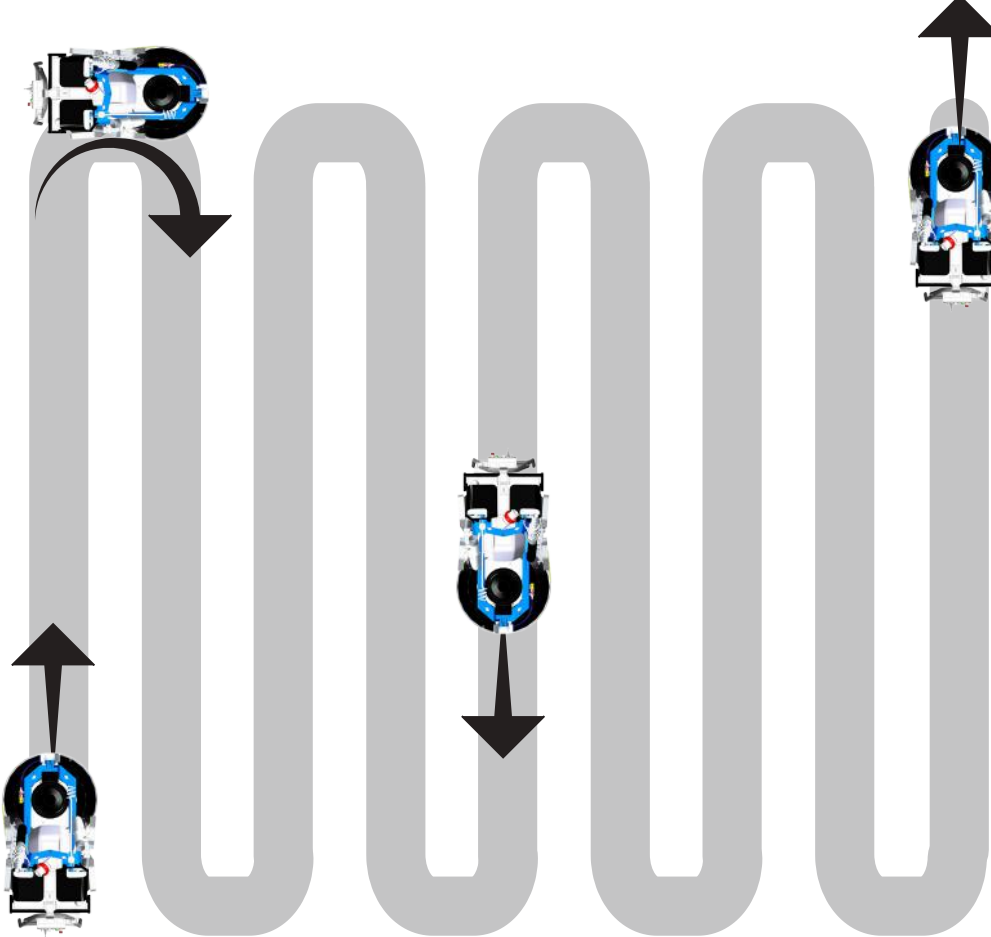

ALL UNDER YOUR CONTROL

HG HYPER GRINDER provides the highest remote control technology for grinders. With this extraordinary system called Autodrive (AD), the HG HYPER GRINDER honing machines can grind the entire work area on their own, going forward, swinging, turning and coming back with overlap. They can grind all the work areas on their own without leaving open areas. Moreover, without any interruption, it is possible to modify all the variables of the machine with the ergonomic and intuitive radio remote control.









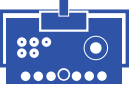

NO
AUTODRIVE



HGE SERIES

EQUIPMENT FOR DIFFERENT VERSIONS

	HGE-M	HGE-RX	HGE-AD
 Autonomous movement by integrated battery	--	✓	✓
 Basic remote control	--	✓	--
 Advanced remote control	--	--	✓
 Automatic advancement	--	✓	✓
 Automatic tilting (Swing)	--	✓	✓
 Automatic inversion (U-Turn)	--	--	✓
 Automatic work track overlap.	--	--	✓
 Automatic grinding of the entire surface	--	--	✓
 Update in Autodrive version (AD)	--	✓	--
 220V power socket attachment	✓	✓	✓

HGE 650

M/RX/AD





NEW DIGITAL DISPLAY (OPTIONAL).



NEW DASHBOARD (STANDARD) WITH CUP HOLDER AND 2 USB SOCKETS.



HG161401 - 45 KG TILTING WEIGHT KIT (OPTIONAL).

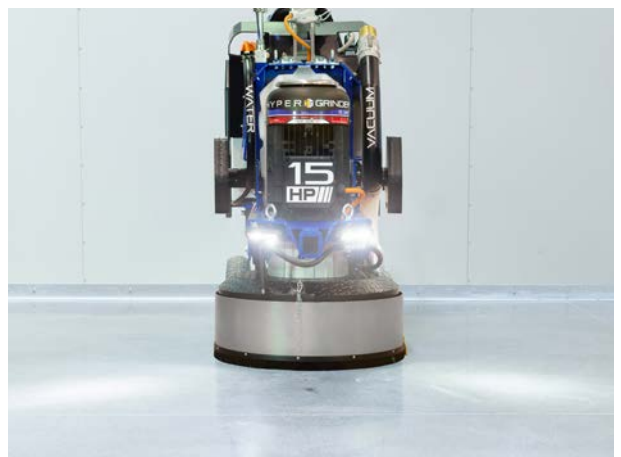

HG132701 - KIT SPRAYER (OPTIONAL)

WHY CHOOSE HGE | SETTING NEW STANDARDS



SECURITY RULES

The HGE series complies with the safety standards Art. EN 60204-1

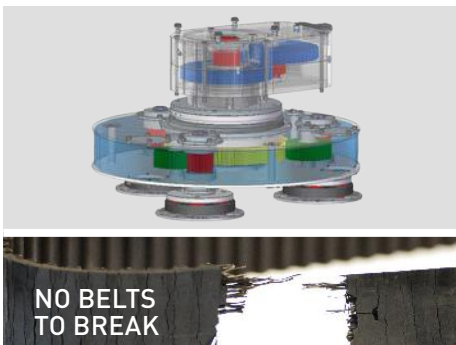

PLANETARY HEAD

PLANETARY HEAD that is 100% tempered metal and geared driven not belt. The main disc and the satellites always run, allowing the machine to work very hard with high performance. The working pressure of the Planetary can be adjusted giving pressure on the front or on the backside. Giving more pressure in front the machine cuts faster and deeper. NO BELTS to break! Check what kind of Planetary they are using. The PALENTARY with BELT DRIVE doesn't have the same performance of metal geared. Furthermore it is subjected to break during the work and needs a lot of time to repair. Attention: many machines don't have the main disc and satellite which run together: if one disk blocks in the satellite, the main disc still runs. This means that when using the machine for heavy duty work the machine won't have performance issues.



SELECTOR TO BLOCK THE DOOR OF THE INVERTER

This device avoids the door from being opened before "switching off" the "electric power". Check if the competitors machine has this device.



SAFETY DEVICE DEDICATED TO MONITOR THE EMERGENCY CIRCUIT

This device automatically shuts off the machine if some electrical problem happens, avoiding any injuries.

HG HYPER GRINDER uses the right and approved electrical components including oversized wire. Check if the competitors machine has this device. Check the electric components and the kind of wire they use is approved.



MOTOR ENGINE

Motor 10 or 15hp even in UL version. Voltage 380-450 volt. Amp 32. Check the kind of motor.



SPECIAL SAFETY EMERGENCY BUTTON

(Not a normal emergency button like on smaller machines). When this special emergency button is pushed the motor is immediately turned off and all the "moving parts" (like tools) are immediately stopped avoiding any injuries. Check if the competitors machine has this device. Many machines in the market that have the emergency button take time to relay the signal therefore could cause injuries.



RE-START SAFETY SYSTEM

Re-start safety system. The new start (re-start) after any stop cannot happen casually. Any start has to be active not passive. This means for example that if any one accidentally connects the electrical power, the machine doesn't start again. To start again the operator has to follow all instructions correctly. Check if the competitors machine has this device. Many machines in the market if after pushing the EMERGENCY BOTTON the electrical power is reconnected accidentally the machine will start again and could cause injury. Pay attention to this hazard, while someone is changing the tools it's possible that someone accidentally restores the power!



VARIABLE SPEED

From 300 up to 1300rpm. Check the speed, many machines have a limited speed range.



TANK WITH 46LT CAPACITY

The tank is very important for working when wet. If working dry the diamond doesn't grip and slips on the surface of the concrete. It is also important for polishing marble, terrazzo and granite. Many competitor machines don't have a tank. Check and see if they have a water tank.



NEW DASHBOARD

HG Hyper Grinder introduces the new dashboard for the grinding machines. Cup holder and 2 USB sockets to make your job even more comfortable.

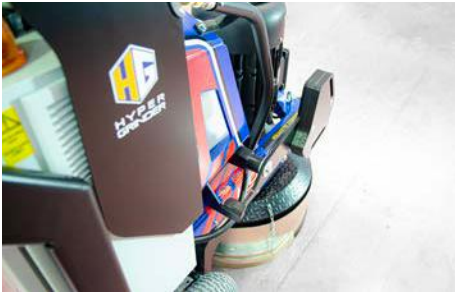

STEEL IMPORTANCE

HGE sanders are designed to be very robust and reliable over time:

- Frame in treated and painted steel.
- Planetary cover in checkerboard metal with cathoporesis treatment to protect it from impacts.

Many sanders have a plastic cover subject to easy breakage, do not protect the tools from shocks and do not allow to work flush against the wall.



RADIO CONTROL AUTODRIVE

The highest technology in the grinding market.

With this fantastic system called "AUTODRIVE" (AD) the grinders are able to grind the whole area by themselves, swinging forward, turning and coming back behind, surmounting the grinding tracks without leaving uncovered areas. Without any interruption, it is also possible to modify all the variables of the grinder with a convenient, compact and intuitive radio control.



OPTIMIZED SUCTION SYSTEM

Connection to the vacuum cleaner in order to work dry and without dust.

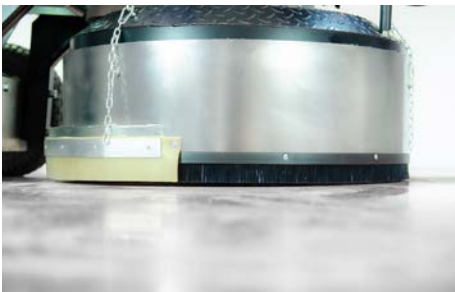

SPLASH GUARD / VACUUM GUARD

Neoprene standard.

Ring with bristles and squeegee optional.

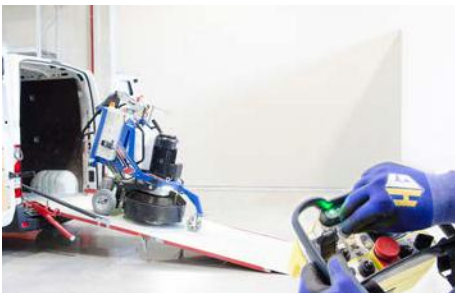

AUTONOMOUS MOVEMENT WITH INTEGRATED BATTERIES

The versions with integrated batteries allow the machine to be moved even in the absence of an electric network. The powerful traction motors allow the machine to move even on uneven surfaces or with a considerable slope, like the platforms of the vans.



ELECTRONICALLY ADJUSTABLE WORKING PRESSURE

Many machines do not have an ELECTRONIC device but need to be manually adjusted or adding extra weights. The HG HYPER GRINDER system allows increased manoeuvrability of the planetary, guaranteeing greater productivity and greater surface flatness.





MAKE YOUR FLOOR SUPER FLAT



The HGE line is ideal for obtaining the maximum flatness of the surfaces in concrete, marble, granite, terrazzo or limestone.

RIGID HEAD VS FLOATING HEAD

With the suspension stiffening system, the yield will be maximized and the surface will become perfectly flat.

Many machines available on the market are built with the free floating planetary head, the machine will follow the undulations of the floor, sometimes leaving a "wavy" appearance. The combination of the floating head and the reduced weight of the machine reduces productivity and the possibility of making the surface flat.

HGE 650

OTHER MACHINES



RIGID HEAD MACHINES
FLOATING HEAD MACHINES
MAKING THE FLOOR FLAT

FLOATING HEAD MACHINES
MAKING THE FLOOR WAVY

NEW 4.0 SYSTEM

OPTIONAL ON THE WHOLE HGE RANGE



GRINDERS

4.0

WHY SWITCH TO 4.0!

DIGITALISE YOUR COMPANY WITH THE NEW RANGE OF FLOOR GRINDERS 4.0



FINANCIAL FACILITATION



THEY CONNECT TO YOUR COMPUTER SYSTEM AND TO THE CLOUD



THEY CAN ALSO BE CONTROLLED REMOTELY



THEY SEND INFORMATION TO YOUR COMPUTER AND YOUR SMARTPHONE



INTEGRATED GPS TO KNOW THE POSITION OF THE GRINDERS



The machine can only be operated using the designated badge of the authorized operator. The control unit sends all information to the management software.



The operator can control the parameters and processing procedures through the convenient and intuitive display. The display also shows the work tasks received remotely.

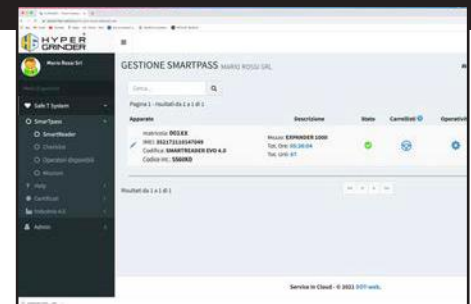

From the management system, you can view information about the sander, send processing procedures to the sander's display, control machine functions, and more

NEW DIGITAL DISPLAY

OPTIONAL ON THE WHOLE HGE RANGE

Hyper Grinder HGE series can be equipped with the new HG touch screen digital display (optional), an innovative device that will allow you to accurately monitor the work of the machine.



The **new HG digital display** (optional) allows you to keep under control all the activities and functions that the machine is performing, even via a remotely connected device.

The new HG display allows you to check in local or remote:

- Speed rotation of tools.
- The percentage of absorption of the maximum value of the motor power.
- The voltage phases.
- Engine temperature.
- The presence or absence of water in the tank.
- The working pressure of the machine.
- The direction of rotation of the planetarium.
- Nebulization of water.
- ON/OFF Suction system.
- ON/OFF led lights.



The display is also equipped with 2 USB ports and a handy tool compartment, useful for recharging the connected device or smartphone.



The dashboard is 180° orientable, it can be easily used both during manual use of the machine and during handling with radio control.

The color display includes a section of consultable documents such as:

- Spare parts and technical sheets.
- User manuals.
- Tool and product catalogues.
- Datasheet.
- Guide to surface processing.

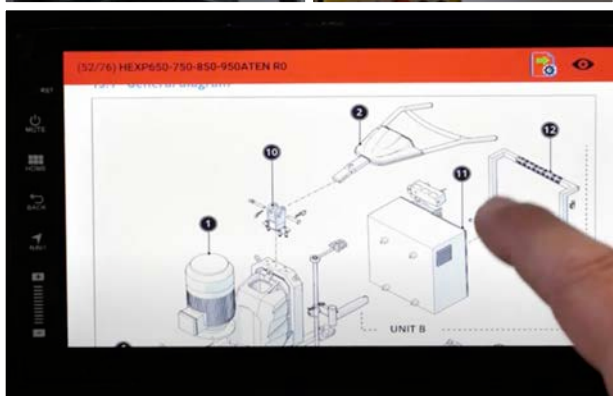

**GUARDA
IL VIDEO**



2 YEARS WARRANTY

The GUARANTEE for HGE grinder with "hour counter" is 2 years or 600 hours.

SETTING NEW
STANDARDS



H Y P E R
G R I N D E R

H G E
6 5 0

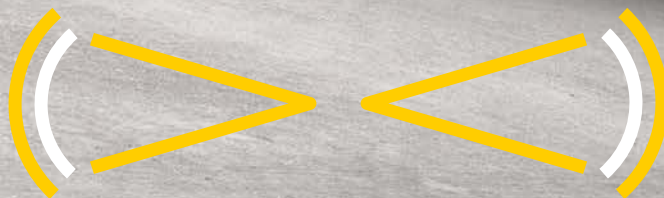

POWERFUL FRONT AND REAR LED
[OPTIONAL]



- 2 x 16A 1Ph 200V sockets • 1 16A 3Ph 5P 400V socket • 1 32A 3Ph 5P 400V socket • V0 self-extinguishing fiberglass cassette • IP 65 protection rating • 2 mt. of H07RN-F cable and CEE IP67 plug • Protected sockets with Interlocked Magnetothermic Differential • Emergency button always present • Grounding screw • Thermo-hardener handle for portable use • Brackets for wall mounting. Particularly suitable for construction sites and uncomfortable environments.

The framework is equipped with the new LED system that helps you to always keep under control the line of your yard. It allows you to immediately identify where the fault is. The LED system also displays the arrival of the earth, allowing you to always work safely.

POWER ADAPTERS

with extension of 25 mt. 5G6 with 32A 5P 400V plug

TFG20101/SPRT Power adapters



- 2 x 16A 1Ph 200V sockets • 1 x 16A 3Ph 5P 400V sockets • 1 x 32A 3Ph 5P 400V sockets • V0 self-extinguishing fiberglass case • IP 65 protection rating • 2 mt. of H07RN-F cable and CEE IP67 plug • Protected sockets with Interlocked Magnetothermic Differential • Emergency button always present • Grounding screw • Thermo-hardener handle for portable use • Brackets for wall mounting. Particularly suitable for construction sites and uncomfortable environments.

The framework is equipped with the new LED system that helps you to always keep under control the line of your yard. It allows you to immediately identify where the fault is. The LED system also displays the arrival of the earth, allowing you to always work safely.

POWER ADAPTERS

Robust 200 from 25 mt. 5G10 3P + N + T with 63A Series HQ plug

TFG20101C Power adapters



EXTENSION FROM 25 MT.

5G6 with 32A 5P 400V plug

PR38073056 Extension



TESTER

network presence on a single phase + neutral + earth

TST-04	Three-phase plug 400V 5 poles 32A
TST-02	Three-phase plug 400V 5 poles 16A
TSM-01	Civil plug 200V 16A
TSM-02	Shuko plug 200V 16A



EXTENSION

Robust 200 from 25 mt. 5G6 3P + N + T with 32A Series HQ plug

CM035701 Extension



EXTENSION

Robust 200 from 25 mt. 3G4 2P + T with 16A Series HQ plug

CM036501 Extension



EXTENSION

Robust 200 from 25 mt. 5G6 3P + N + T with 16A Series HQ plug

CM036101 Extension



EXTENSION

Robust 200 from 25 mt. 5G10 3P + N + T with 63A Series HQ plug

CM035301 Extension



MULTIPLE

3 outputs 3P + N + T with 400V / 200V cable

VB1850 Multiple



MULTIPLE

with 3 outputs 1P + N + T with 200V cable

VB1552 Multiple

HGE TOOLS

			
BUSH HAMMER exclusive tool useful for many applications.	SANDBLASTING sandblasting effect	PDC SCRAPER for resin removal and thick coatings.	PDC HYPER SCRAPER for resin removal and thick coatings.
			
TCK ARROW for resin removal and paints on hard concrete floors	BT ROUND for the removal of lower thickness resins and paints.	TCK SERIES preparations and removal of coatings on concrete floors.	HG-M diamond tools for medium abrasive concrete.
			
HG-H diamond tools for grinding HARD floors.	HG-S diamond tools for soft concrete.	HG-A diamond tools for very abrasive and asphalt concrete.	HG-P for standard concrete.
			
TRAPEZOIDS	SPRING HOLD SYSTEM for perfect and homogeneous concrete polishing.	JUMPY GREEN for smoothing and polishing concrete floors.	SERIES MM metal diamond discs for polishing marble.
			
JUMPY YELLOW Resin disks for polishing marble floors.	SERIES MTM To smooth terrazzo, agglomerate, limestone, travertine and abrasive floors.	JUMPY ORANGE for polishing granite, Terrazzo, Limestone and Sown.	SERIES GM Metal diamond discs for smoothing granite and stoneware.
			
JUMPY RED Resin diamond disks for polishing granite and stoneware.	PAVELUX to remove mastic or polish marble and granite.	ANTIQUÉ BRUSH system for anti-queing marble, stone and terracotta.	TOOLS BOX Complete kit for grinding and polishing.



HG HYPER GRINDER S.R.L.
Via Ragazzi del '99, 7 | 65123 Pescara (PE) | ITALY
P.Iva 02223280682 | hypergrinder@pec.it | Tel +39 085 8218160
www.hypergrinder.com | info@hypergrinder.com



Your Distributor: _____



rev.15092023